

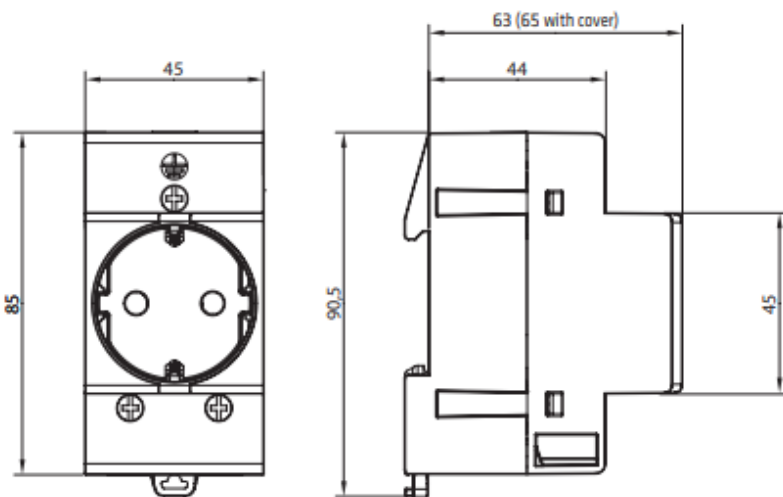

DIN montert stikkontakt 2p+j
Standard: IEC 60884-1
Spesifikk standard: DIN VDE 0620-1
Moduler: 2,5
Varenr: 1573459

Standard	IEC 60884-1. DIN VDE 0620-1	Farge	Hvit
Type:	Stikkontakt 2P+j	Spenning	250VAC
Strøm	16A	Tiltrekningsmoment	0,8
En leder kable	16mm ²	Fler trådet kabel	10mm ²
Moduler	2,5		

Dimensjon



Standarder/godkjenninger

